

# DT SERIES, 4-WIRE

## DC Current Transducers

DT Series DC Current Transducers combine a Hall effect sensor and signal conditioner into a single package for use in DC current applications up to 400 A. The DT Series DC Current Transducers unipolar and bipolar models have jumper selectable current input ranges and industry standard 0–20 mA, 4–20 mA, 0–5 VDC or 0–10 VDC outputs. The DT Series DC Current Transducers are available in split-core or solid-core enclosures.



### DC Current Transducer Applications

#### Battery Banks

- Monitors load current.
- Monitors charging current.
- Verifies operation.

#### Transportation

- Measures traction power or auxiliary loads.

#### Welding Processes

- Measures the current used while welding.
- Log processing time and number of operations.

#### Photovoltaic Panels

- Monitor panel or string current output.
- Monitor combiner box output.

### DC Current Transducer Features

#### Single Range or Three Jumper Selectable Ranges

- Reduces set-up time.
- Reduces inventory.
- Eliminates zero and span pots.

#### Isolation

- Output is magnetically isolated from the input for safety.
- Eliminates insertion loss (voltage drop).

#### Internal Power Regulation

- Works well, even with unregulated power.
- Cuts installation cost.

#### Split-core Design/Built-in Mounting Brackets

- Makes installation a snap.

Battery Charging System - Bipolar Output

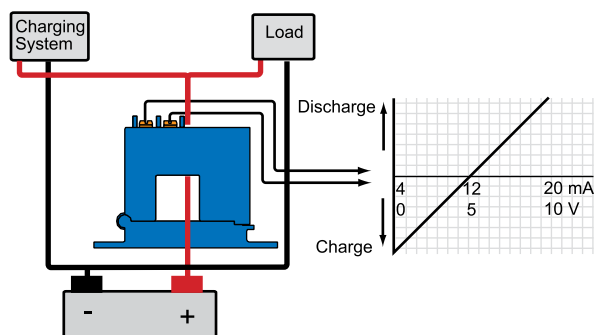

Battery Charging System - Bidirectional Output

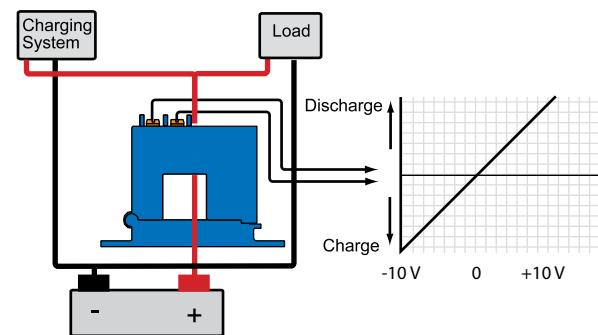

Free program expedites evaluation process. See page 1 for details.

DC Current Transducer Dimensions

FL Case

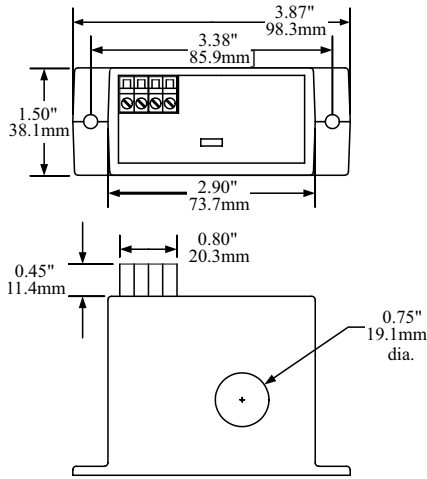

SP Case

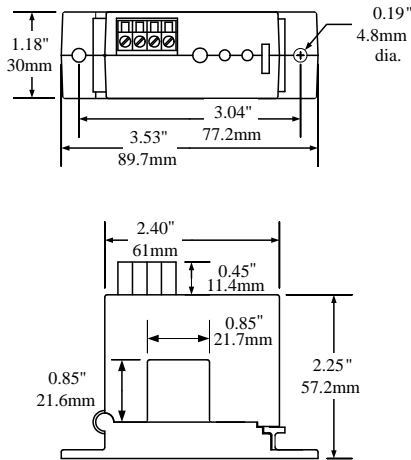

DC Current Transducer Connections

DT Series Unipolar and Bipolar Output Models

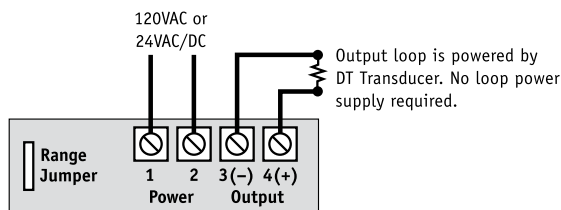

Notes:  
 Deadfront captive screw terminals.  
 12–22 AWG solid or stranded.  
 Observe polarity.

DC Current Transducer Unipolar Output

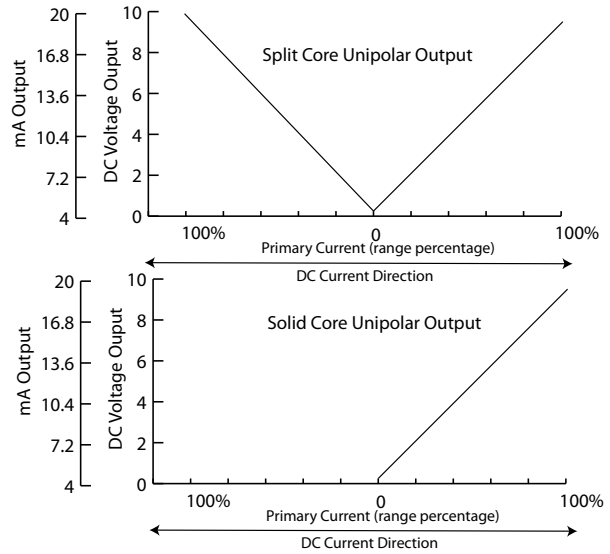

DC Current Transducer Specifications



Output Signal	<ul style="list-style-type: none"> <li>0–20 mA, 4–20 mA, 0–5 VDC, 0–10 VDC</li> <li>±10 VDC (Bidirectional models only)</li> </ul>
Output Limit	<ul style="list-style-type: none"> <li>0–20 mA, 4–20 mA: 23 mA</li> <li>0–5 VDC: 5.75 VDC</li> <li>0–10 VDC: 11.5 VDC</li> </ul>
Accuracy	<ul style="list-style-type: none"> <li>Solid-core: 1% FS</li> <li>Split-core: 2% FS</li> </ul>
Repeatability	1.0% FS
Response Time	<ul style="list-style-type: none"> <li>Solid-core: 20 ms (to 90% of step change)</li> <li>Split-core: 100 ms (to 90% of step change)</li> </ul>
Frequency Range	DC
Power Supply	<ul style="list-style-type: none"> <li>120 VAC (split-core only)</li> <li>24 VAC/DC, 2 VA max.</li> </ul>
Power Consumption	2 VA
Loading	<ul style="list-style-type: none"> <li>0–20 mA, 4–20 mA: 500 max.</li> <li>0–3 or 5 VDC: 25 KΩ min.</li> <li>0–10 VDC: 50 KΩ min.</li> </ul>
Isolation Voltage	3 KV (monitored line to output)
Linearity	0.75% FS
Current Ranges	<ul style="list-style-type: none"> <li>Solid Core 0–200 max.</li> <li>Split Core 0–50 min., 0–400 max.</li> </ul>
Sensing Aperture	<ul style="list-style-type: none"> <li>FL Case: 0.75" (19.1 mm) dia.</li> <li>SP Case: 0.85" (21.6 mm) sq.</li> </ul>
Case	UL94 V0 Flammability Rated
Environmental	-4 to 122°F (-20 to 50°C) 0–95% RH, non-condensing
Listings	UL 508 Industrial Control Equipment (USA & Canada), CE

DC Current Transducers



**DC Current Transducer Ordering Information**

**DT Series Unipolar and Bipolar Output Models, Split-Core Models**

Sample Model Number: DT2-420-24U-U-SP

DC current transducer, 0–100/150/200 A range, 4–20 mA output, 24 VAC/DC powered, unipolar polarity, split-core case.

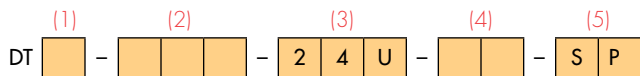

(1) Full Scale Range

1	50, 75, 100 A
2	100, 150, 200 A
3	150, 225, 300 A
4	200, 300, 400 A

(2) Output Signal

020	0–20 mA
420	4–20 mA

003	0–3 VDC
005	0–5 VDC
010	10 VDC

(3) Power Supply

24U	+24 VAC/DC
-----	------------

(4) Output Polarity

U	Unipolar (Output with current in either direction)
BP	Bipolar

(5) Case Style

SP	Split-core
----	------------

**DT Series Unipolar and Bipolar Output Models, Solid-Core Models**

Sample Model Number: DT2-420-24U-U-FL

DC current transducer, 0–100/150/200 A range, 4–20 mA output, 24 VAC/DC powered, unipolar polarity, solid-core case.

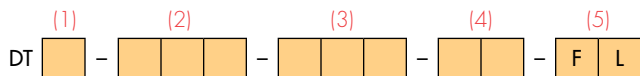

(1) Full Scale Range

0	5, 10, 20 A
1	50, 75, 100 A
2	100, 150, 200 A

(2) Output Signal

020	0–20 mA
420	4–20 mA
003	0–3 VDC

005	0–5 VDC
010	10 VDC

(3) Power Supply

24U	+24 VAC/DC
120	120 VAC

(4) Output Polarity

U	Unipolar (Output with current in one direction only)
BP	Bipolar

(5) Case Style

FL	Solid-core
----	------------

**DT Series Bidirectional Output Models**

Sample Model Number: DT2-010-24U-BD-SP

DC current transducer, 0–200 A range, ±10 VDC output signal, 24 VAC/DC powered, split-core case.

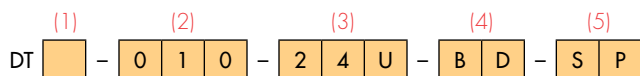

(1) Full Scale Range

1	100 A
2	200 A
3	300 A
4	400 A

(2) Output Signal

010	10 VDC
-----	--------

(3) Power Supply

24U	+24 VAC/DC
-----	------------

(4) Output Polarity

BD	Bidirectional
----	---------------

(5) Case Style

SP	Split-core
----	------------

Contact:  
 Industrial Process Measurement, Inc.  
 3910 Park Avenue, Unit 7  
 Edison, NJ 08820  
 732-632-6400  
 support@instrumentation2000.com  
 http://www.instrumentation2000.com

